

Breathing Air and Filtering Respiratory Protective Equipment

Working Together for Safety Recommendation 009E/2024



SfS
Samarbeid for Sikkerhet

| | | |
|---|--|---|
| Prepared by the Working Together for Safety Working Group: January 2024 | Version: Rev 02 | Working Together for Safety Project Manager: <i>Hugo Halvorsen</i> Hugo Halvorsen (signature on file) |
| Applies from: 12 June 2024 | Version history: Rev 00: Sep 2003 Rev 01: Dec 2017 | Approved by the Working Together for Safety Board, Chairman: <i>Håkon Bjerkeli</i> Håkon Bjerkeli (sign. on file) |

Contents

| | |
|--|-----------|
| 1. Introduction | 3 |
| 2. Purpose | 3 |
| 3. Target group | 3 |
| 4. Changes in this revision | 3 |
| 5. Definitions | 4 |
| 6. Respiratory protective equipment with a compressed air supply and filtering respiratory protective equipment | 5 |
| 6.1 Introduction to respiratory protective equipment | 5 |
| 6.2 Filtering respiratory protective equipment | 5 |
| 6.3 Respiratory protective equipment with a compressed air supply | 6 |
| 7. Leak and fit testing of masks | 8 |
| 8. Training | 9 |
| 9. Operation of systems that supply breathing air | 9 |
| 10. References and links | 10 |
| 11. Appendices | 11 |
| Appendix 1: Overview of various filter types | 12 |
| Appendix 2: Overview of various types of respiratory protective equipment | 15 |
| Appendix 3: Sample checklist for users of breathing air systems | 18 |
| Appendix 4: Example of breathing air system – input for risk analysis | 20 |
| Appendix 5: Checklist – design and operation of breathing air systems | 21 |
| Appendix 6: Technical info | 24 |
| Appendix 6.1 Dimensioning | 24 |
| Appendix 6.2 Maintenance of breathing air systems | 24 |
| Appendix 6.3 Couplings and hoses for use with breathing air | 24 |
| Appendix 6.4 Bottle banks | 26 |

1. Introduction

Respiratory protective equipment shall be used during all work that involves a risk of exposure to harmful substances via inhalation. Respiratory protective equipment is divided into filtering respiratory protective equipment and respiratory protective equipment with a compressed air supply (breathing air), with associated sub-categories as described in this recommendation.

Breathing air (respiratory protective equipment with a compressed air supply) provides greater protection than filtering masks. Breathing air shall always be used when performing work in atmospheres with oxygen levels below 19.5%, in atmospheres containing high levels of contaminants (e.g. when entering confined spaces), in atmospheres with highly toxic levels of contaminants (e.g. H₂S), or where the use of filtering masks is considered insufficient for other reasons. When using respiratory protective equipment with an oxygen level between 20.9% and 19.5%, an assessment should be undertaken to determine which substances may have replaced the missing oxygen volume.

The employer is responsible for providing the correct respiratory protective equipment in accordance with the type of work operation, contaminants and exposure level. The employer also has a responsibility to ensure that employees receive the necessary training in the specific personal protective equipment they shall use.¹

This recommendation describes various types of respiratory protective equipment, with particular emphasis on the use of breathing air and the design and maintenance of breathing air systems.

2. Purpose

The purpose of this recommendation is to help ensure the correct selection and use of respiratory protective equipment to prevent harm to health. Equipment for use during rescue and evacuation is not covered in this recommendation.

3. Target group

The target group for this recommendation is primarily everyone who uses respiratory protective equipment. This recommendation also contains helpful tips for those who plan/design and maintain breathing air systems.

4. Changes in this revision

This recommendation has been revised and expanded in order to provide clearer information for users of breathing air and filtering respiratory protective equipment. A separate checklist has been prepared for users of breathing air, see Appendix 3. The

references and information about respiratory protective equipment have been updated, with emphasis placed on Norwegian and European regulations and standards.

5. Definitions

Nominal/theoretical protection factor (NPF): Specifies by how many times the respiratory protective equipment is able to reduce the concentration of harmful substances in the mask compared to the concentration in the surroundings. The theoretical protection factor is determined during laboratory testing, and is always higher than the factor that will be achieved during normal use of the equipment.

Assigned/practical protection factor: Specifies the level of protection that the respiratory protective equipment is able to provide in practice when functioning correctly and used by trained users as instructed.

Regulator: A valve that delivers the correct volume of air in relation to the user's need, while simultaneously always maintaining positive pressure inside the mask, regardless of the user's respiration rate. This must not be confused with respiratory protective equipment with a compressed air supply with continual air flow, which provides only a constant flow of air, regardless of respiration rate and need.

Classified area: Areas where an explosive atmosphere may occur.

Zone 0: Explosive atmosphere continually present, or present for extended periods.

Zone 1: Explosive atmosphere likely during normal operations.

Zone 2: Explosive atmosphere only under exceptional circumstances and for short periods.

Unclassified area: Areas where hydrocarbons are not usually present.

Fit test: Also called a self-test or leak check. A simple test to check the seal of the face mask, performed by the wearer prior to use.

Leak test (Objective leak test): A systematic qualitative or quantitative measurement of the face mask's seal against the skin of the individual user. This test must be carried out by competent personnel with training in the testing method.

For more information about fit testing, see Offshore Norge 113 [Recommended Guidelines for Fit Testing of Respiratory Protective Equipment](#).

6. Respiratory protective equipment with a compressed air supply and filtering respiratory protective equipment

6.1 Introduction to respiratory protective equipment

The purpose of respiratory protective equipment is to protect the user from inhaling hazardous gases, vapours and particles from the surroundings. Respiratory protective equipment can be divided into two categories, each of which has two sub-categories, see the overview below.

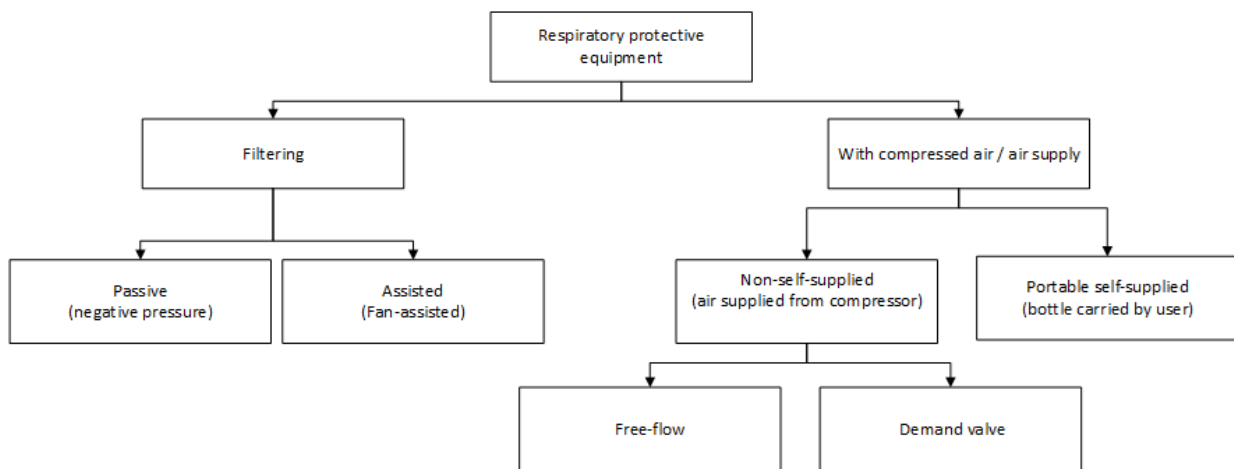

In general:

- Filtering respiratory protective equipment with negative pressure will offer the lowest level of protection.
- Assisted filtering respiratory protective equipment will offer a medium level of protection (note that this depends on the class/type of equipment).
- Respiratory protective equipment with a regulator and positive pressure will offer the highest level of protection.

It is the employer's responsibility to ensure the necessary maintenance of all respiratory protective equipment.

6.2 Filtering respiratory protective equipment

Filtering respiratory protective equipment filters the surrounding air. In order to use filtering respiratory protective equipment, the type of contaminants the worker requires protection against must be known, so that the correct filter can be chosen. The type of respiratory protective equipment and filter type shall be specified in point 8 of the safety data sheet. An overview of various types of particle and gas filters is provided in Appendix 3. A condition for using filtering respiratory protective equipment is that the oxygen level in the air is at least 19.5%.

There are two main types of filtering respiratory protective equipment:

- Passive masks (masks with negative pressure – underpressure), where the user breathes through integrated or replaceable filters in the body of the mask.
- Fan-assisted respiratory protection, where a battery-operated fan draws in air through the filters and supplies it to the mask.

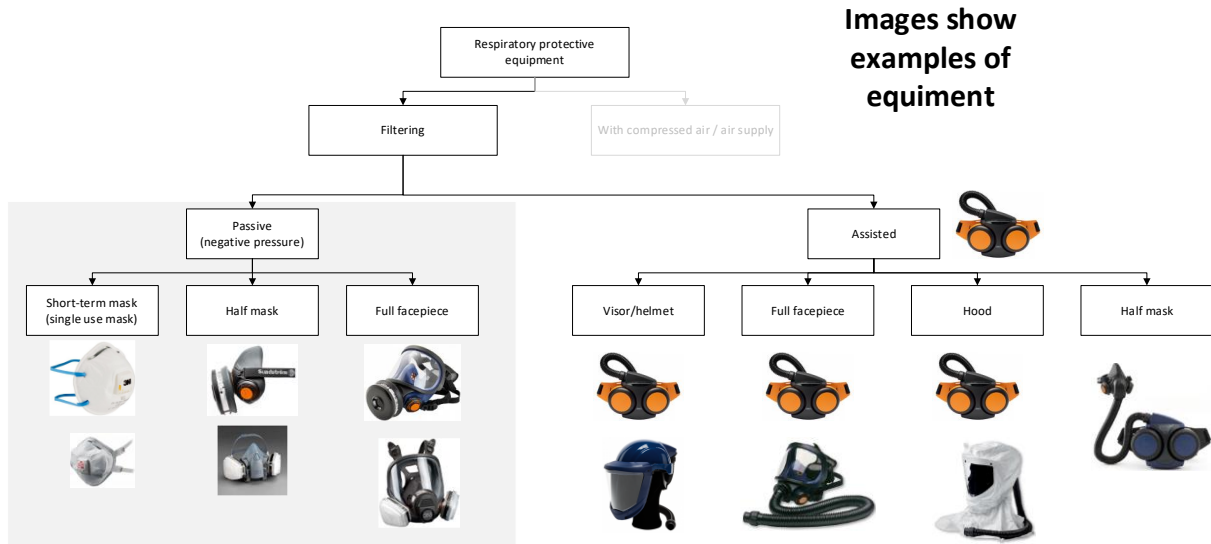

The advantages and disadvantages of protective equipment are given in Appendix 2.

6.3 Respiratory protective equipment with a compressed air supply

Respiratory protective equipment with a compressed air supply is equipment that supplies the worker with a constant supply of air from non-contaminated sources via a distribution system. The breathing air is supplied to the worker’s mask, helmet, hood or screen, and may come from a compressor, larger pressurised containers (bottle bank), or portable bottles carried on the user’s body.

Overview of respiratory protective equipment with a compressed air supply:

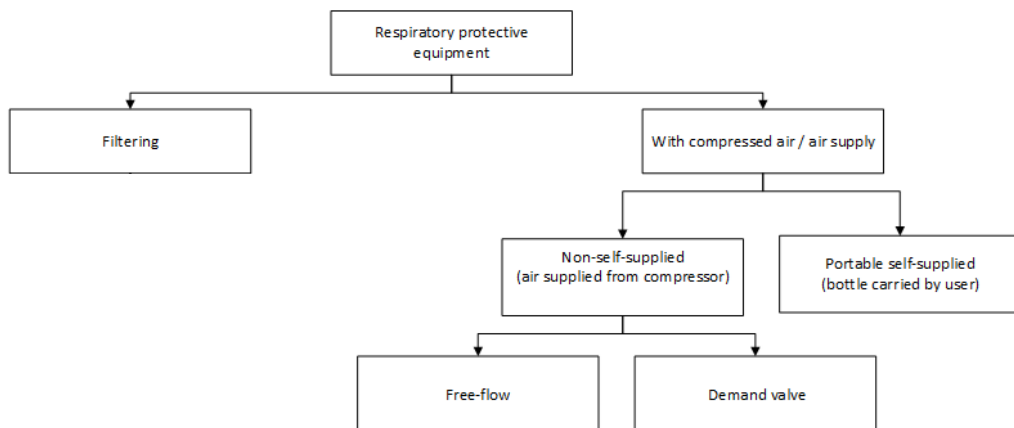

In the following situations, respiratory protective equipment with a compressed air supply shall always be used because it is the only equipment that will provide sufficient protection:

- In the event of oxygen concentrations below 19.5%.
- In cases where the nature and concentration of the contaminants are unknown and expected or suspected to be high.
- In cases where the contaminants are odourless, and their concentration is unknown.
- In cases where contaminants are unable to be filtered (e.g. CO, NO₂) or there is a risk that oxygen may be superseded by other gases.
- When work-specific procedures require it (e.g. spray-painting and welding).

In the event of extremely high relative humidity (95–100%), gas filters will become saturated more quickly, and particle filters will also become clogged or be destroyed more quickly. Electrostatic particle filters are also particularly vulnerable under such conditions. This effect is intensified in the event of high temperatures, and in such conditions respiratory protective equipment with a compressed air supply should normally be used.

NB: It must be checked that the compressor is able to deliver a sufficient volume of air to supply the equipment that will be used. For example, the use of free-flow equipment will usually require more air than when using a regulator.

The breathing air shall be clean and free of any smell or taste, and satisfy the requirements in section 5-5 of the Regulations concerning action and limit values² and NS-EN 12021:2014⁶.

When working in areas with an acute risk of low oxygen or the presence of toxic gases/vapours, the need for a back-up solution must always be assessed. If only “non-self-supplied” breathing air is used, there is no back-up in the event of a hose failure. A solution in which back-up air is self-supplied and carried on the user’s body therefore always provides the greatest safety. The use of respiratory protective equipment shall be risk-assessed in all cases, ref. EN529. If the back-up air is placed in other locations, the risk of hose failures or that alarms will not be heard, etc. must be considered. The back-up air must be sufficient to ensure a possible escape to open air.

Example of "flite" with combined self-supplied and "not self-supplied" air supply

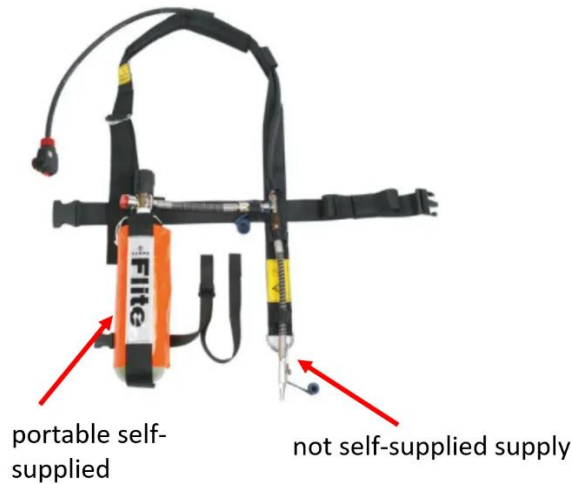

If the combination of “non-self-supplied” and “self-supplied” breathing air is used as a contingency function in connection with emergency escape, the assessment shall also document that the bottle has sufficient volume for the user to perform the emergency escape using the relevant facepiece.

7. Leak and fit testing of masks

Leak and fit testing of respiratory protective equipment is relevant for half masks and full facepieces with negative pressure (underpressure). Mask leaks due to the mask not being adapted to the wearer will result in the mask not providing the expected protection. A common challenge is that the mask does not correctly fit the worker's face, causing leaks to arise between the body of the mask and the wearer's skin. Filtering half masks and full facepieces cannot be used by people with facial hair or stubble, since this can prevent good contact from being established between the respiratory protective equipment and the wearer's face.

We mainly differentiate between fit testing performed by the wearer and objective leak testing of the respiratory protective equipment.

For filtering respiratory protective equipment, excluding (fan) assisted respiratory protective equipment, a fit test shall be performed by the wearer. This test shall be performed prior to every use. The procedure for the fit test is described in the equipment manufacturer's user guide for the relevant respiratory protective equipment, but this typically involves blocking the filter/air intake with a hand and breathing in. The mask should then sit tightly against the skin for at least ten seconds without “letting go”.

Objective leak testing of respiratory protective equipment should be carried out whenever a new type of mask is used, and be repeated regularly and in the event of any change to the shape of the user's face. Leak testing may be performed in accordance with recognised standards and with the assistance of competent personnel. Offshore Norge's 133 – Recommended guidelines for fit testing of respiratory protective equipment, describe this in more detail.

8. Training

Users of respiratory protective equipment must receive sufficient basic and refresher training. The training should be provided by competent personnel and cover:

- Selection of the correct type of respiratory protective equipment (ref. Appendix 2)
- Correct use, including limitations on the length of time for which the equipment may be used
- Correct cleaning and maintenance
- Routines for filter replacement
- Safe storage

This is to ensure that the respiratory protective equipment provides sufficient protection, and is used in accordance with the manufacturer's guidance. Personnel who handle (purchase, manage, distribute, etc.) respiratory protective equipment on behalf of the company must also have sufficient knowledge/training to be able to adequately perform their tasks.

9. Operation of systems that supply breathing air

Stationary breathing air outlets should be clearly labelled and "tagged" as outlets for breathing air. Always check that breathing air hoses are not in use before shutting off the air supply and disconnecting the hoses. The labelling of the electricity supply (outlets/breakers, etc.) for electrical breathing air equipment must be considered in order to prevent sudden stoppages/cuts in the event of faults. The same applies to breathing air hoses / distribution valves. All respiratory protective equipment must be used, cleaned and maintained in accordance with the manufacturer's user manual and instructions.

The owner/operator of the facility is responsible for being able to inform users of how the instrument/breathing air system elements are put together, so that users can be sure that they are using the system safely. Users must have the necessary physical fitness to be able to use the selected equipment / perform the work.

In the event of any alarm regarding the quality of the breathing air, the area responsible must be contacted before the work is resumed. Users are responsible for establishing effective routines for perceiving any alarms that are sounded/identified, and for terminating use of the equipment quickly and safely. Manual checks of the breathing air's quality shall also be considered prior to commencing the work.

If a risk assessment performed prior to commencing the work identifies a need for back-up/escape equipment, e.g. for work in tanks with toxic atmospheres, routines for this must be clarified in advance.



For transportable (temporary) compressor systems / bottle banks:

- Special attention must be paid to the placement of the air intake with regard to possible contaminants, e.g. from exhaust outlets in the event of unfavourable wind directions.
- If there are several work teams associated with the same system, the necessity of a dedicated watchperson to coordinate, monitor and notify the various work teams in the event of any incident must be considered.
- Mobile breathing air compressors shall be placed in a safe area. A safe area is defined as an area a minimum of 3 metres from classified areas, where there are no exhaust fumes or other contaminants. The compressor's air intake shall face away from any sources of emissions. There shall be free air around the entire compressor.
- Mobile breathing air compressors should not be placed in noisy areas where double hearing protection is required (due to sounded alarms).
- Mobile breathing air compressors shall be equipped with an alarm/whistle that directly alerts the user and entry guard in the event of low pressure or a loss of breathing air. If the mobile compressor is located so that the entry guard is unable to hear the whistle, a dedicated watchperson who is in communication with the entry guard shall be established at the compressor (the communication may be either visual contact or radio communication).
- Mobile breathing air compressors should feature meters for minimum CO/CO₂ and dew point.
- Breathing air compressors should be oil-free (i.e. oil is not in contact with the breathing air) in order to ensure that the breathing air system does not become contaminated.
- If oil-lubricated air compressors are used for breathing air, a risk assessment shall be performed to ensure that the breathing air system does not become contaminated. Manual oil measurements should be performed before the compressor is used and the frequency of further measurements shall be addressed in the risk assessment.
- The alarm whistle on mobile air compressors shall be tested before use.

10. References and links

1. Regulations concerning the performance of work (Chapters 3, 10 and 25)
2. Regulations concerning action and limit values (Section 5-5)
3. Regulations concerning administrative arrangements (Section 10)
4. The Norwegian Labour Inspection Authority's Guidance on respiratory protective equipment
5. Offshore Norge Guideline 133 – Recommended guidelines for fit testing of respiratory protective equipment
6. Respiratory equipment – Compressed gases for breathing apparatus NS-EN 12021:2014
7. Respiratory protective devices — Compressed air line breathing devices with demand valve — Part 1: Devices with a full face mask — Requirements, testing and marking, NS-EN 14593-1:2018

8. Respiratory protective devices – Continuous flow compressed air line breathing apparatus, NS-EN 14594:2018
9. Respiratory protective devices – Recommendations for selection, use, care and maintenance, NS-EN 529:2005
10. Respiratory protective devices - Gas filter(s) and combined filter(s) - Requirements, testing, marking, EN 14387:2021
11. Respiratory protective devices — Continuous flow compressed air line breathing devices — Requirements, testing and marking, NS-EN 14594:2018
12. Respiratory protective devices — Recommendations for selection, use, care and maintenance — Guidance document EN 529:2005

11. Appendices

Appendix 1: Overview of various filter types and usage limits

Appendix 2: Overview of various types of respiratory protective equipment (+ - and protection factor)

Appendix 3: Sample checklist for users of breathing air

Appendix 4: Example of breathing air system – input for risk analysis

Appendix 5: Checklist – design and operation of breathing air systems

Appendix 6: Technical appendices

- Dimensioning
- Maintenance of breathing air systems
- Couplings and hoses for use with breathing air
- Bottle banks

Appendix 1: Overview of various filter types

Overview of gas filters with colour codes:

| Letter code | Colour code | Protects against |
|--------------|---|--|
| A | Brown | Gases and vapours from organic substances with a boiling point > 65°C, such as organic solvents from work involving paints, coatings and glues |
| AX | Brown | Gases and vapours from organic substances with a boiling point ≤ 65°C |
| B | Grey | Specific inorganic gases and vapours as specified by the manufacturer, such as chlorine, hydrocyanic acid and hydrogen sulphide |
| E | Yellow | Sulphur dioxide and other acid gases and vapours as specified by the manufacturer |
| K | Green | Ammonia and certain amines as specified by the manufacturer |
| Hg | Red (red- white if combined with particle filter) | Mercury |
| SX | Violet (violet- white if combined with particle filter) | Filter for specific substances, specified by the filter manufacturer |
| Formaldehyde | Olive green | Formaldehyde |

Source: Norwegian Labour Inspection Authority

Classification of gas filters – Concentration of test gases:

For passive masks (EN14387):

| | |
|---------|--|
| Class 1 | Concentrations below 0.1 vol. % (1,000 ppm) |
| Class 2 | Concentrations below 0.5 vol. % (5,000 ppm) |
| Class 3 | Concentrations below 1.0 vol. % (10,000 ppm) |

For fan-assisted masks (EN12941, EN12942):

| | |
|---------|---|
| Class 1 | Concentrations below 0.05 vol. % (500 ppm) |
| Class 2 | Concentrations below 0.1 vol. % (1,000 ppm) |
| Class 3 | Concentrations below 0.5 vol. % (5,000 ppm) |

Overview of particle filters that protect against solid particles and fluid particles, colour code white.

| Filter class | Filtration effectiveness | Comments and examples |
|--------------|--------------------------|---|
| P1 | Low | Used only if the dust/aerosols are harmless (often unsuitable in working environment) |
| P2 | Medium | Protects against most types of dust/aerosols with low toxicity |
| P3 | High | Used when dust/aerosols contain or may contain toxic or extremely toxic particles, carcinogenic substances, radioactive particles, bacteria or viruses. |

Source: Norwegian Labour Inspection Authority

Filter lifetime:

There is no set answer as to how long a filter may be used before it must be replaced.

Factors that affect a filter's lifetime include:

- Concentration of contaminants in the air
- Breathing rate: in the event of heavy work, more air will be drawn through the filter
- Temperature: At high air temperatures the absorptive power of the filter material may reduce, but this is rarely a major problem in Norway. One must however be aware of this indoors, e.g. in areas such as shaker rooms.
- Humidity:
 - Gas filters: water molecules in the air will occupy space in the carbon filter in the same way as the organic compounds. Most filters are labelled with the maximum humidity
 - Dust filters made of electrostatic material – over time, the humidity will reduce the electrostatic qualities of the filter.



These factors apply to both dust filters and gas filters, but in practice and in daily use it is difficult to maintain an overview of how these factors will affect the filter. NB: Hg filters have a maximum use time of 50 hours, and all AX-filters are single use only¹⁰.



Practical, simple rules for how often filters should be replaced:

- The filter is marked with an expiry date. It is recommended that filters are not used after this date – even if the filter packaging is unopened
- If the filter is visibly damaged or contaminated/dirty, it must be replaced
- Between each use, filters should be stored in a closed plastic bag to prevent them becoming damp, which will shorten their lifetime. Storing masks in humid changing rooms or outdoors will over time shorten the filters' lifetime.
- For filters that are used for short-term jobs – a few minutes each time, e.g. opening flanges or sampling, limited to a few times per day – a good rule of thumb can be to replace the filter every week or every 14 days (at the end of the shift rotation)

It can be a good idea to label the filter with the date on which it was first used.

Appendix 2: Overview of various types of respiratory protective equipment

| Example of equipment | What | Advantages | Disadvantages |
|---|--|--|---|
|  | <p>Filtering half masks with an integrated filter in the mask body</p> <p>Practical protection factor (APF): Class P1: 4 Class P2: 10 Class P3: 20</p> | <ul style="list-style-type: none"> - Does not require maintenance or cleaning. - The masks can be used several times, but must be discarded when the filter is thought to be worn out or when the job is completed. - Easy to carry, and therefore offer a low threshold for use of the mask. | <ul style="list-style-type: none"> - Often only available in one size, which may pose a greater risk of the mask not being a good fit for the user and therefore a greater risk of leaks. The mask may consequently not provide adequate protection. - Facial hair will increase the risk of mask leaks, and it is therefore not recommended to use this type of mask if you have facial hair. |
|  | <p>Half masks with negative pressure</p> <p>Practical protection factor (APF): Class P1: 4 Class P2: 10 Class P3: 20</p> | <ul style="list-style-type: none"> - Half masks are lightweight and relatively easy to put on and to carry. | <ul style="list-style-type: none"> - The use of combination filters (heavy filters) in half masks can make them front-heavy, leading to an increased risk of leaks – especially at the root of the nose. - Facial hair will increase the risk of mask leaks, and it is therefore not recommended to use half masks if you have facial hair. |
|  | <p>Full facepiece with negative pressure</p> <p>Practical protection factor (APF): Class P1: 4 Class P2: 15 Class P3: 400</p> | <ul style="list-style-type: none"> - It is normally easier to get a full facepiece to seal around the face than a half mask. - Also protects the eyes and the skin of the face against chemical splashes/particles. | <ul style="list-style-type: none"> - Full facepieces are larger and heavier, and block some of the wearer's field of view. Many therefore refuse to wear full facepieces, and instead choose half masks. - In the event of intense physical work, full facepieces may become fogged up. - Facial hair will increase the risk of mask leaks, and it is therefore not recommended to use full facepieces if you have (a lot of) facial hair. |

| Example of equipment | What | Advantages | Disadvantages |
|---|--|---|--|
|  | <p>(Fan) assisted filtering respiratory protective equipment</p> <p>Practical protection factors (APF):</p> <p>Visor TH 1: 5 Visor TH 2: 20 Visor TH 3: 200</p> <p>Full facepiece TM1: 5 Full facepiece TM2: 100 Full facepiece TM3: 500</p> | <ul style="list-style-type: none"> - Easier to breathe in than filter masks, which offer a certain amount of resistance since the wearer must inhale the air through a filter unassisted. - Due to free-flow (in the breathing zone) in the mask, mask leaks will not usually pose a problem. - Well suited to users with facial hair. - The filter is usually placed on a belt around the wearer's waist, preventing the mask from being front-heavy. - Possibility to use a visor, which offers good visibility compared to half masks and full facepieces. - The use of motor-assisted respiratory protection equipment ensures that fogging of the mask is significantly reduced. | <ul style="list-style-type: none"> - In the oil and gas industry, the battery pack and accessories (including hoses and facepiece) must be ATEX-certified, which limits the selection of equipment. - Routines for cleaning/disinfection/maintenance/battery charging and filter changes must be followed in order to ensure that the equipment is safe to use. - A limited selection of hearing protection can be attached to helmets with visors – especially if hearing protection with communication is required. |
|  | <p>Respiratory protective equipment with compressed air supply</p> <p>Practical protection factors (APF): Class 3A/3B: 100</p> | <ul style="list-style-type: none"> - Provides good protection under almost any conditions. - No need to determine which filter is required, or whether this will protect against all contaminants. | <ul style="list-style-type: none"> - Fixed connection to air hose can limit range of movement. |

| Example of equipment | What | Advantages | Disadvantages |
|--|--|--|--|
| | <p>Class 4A/4B: 1000 Class 1A/1B and 2A/2B not recommended</p> <p>This applies to free-flow equipment (ref EN 14594:2018) and full facepieces with regulators (ref EN 14593-1)</p> | <ul style="list-style-type: none"> - No need to consider filter lifetime. | |
|  | <p>Respiratory protective equipment with compressed air supply and regulator</p> <p>Practical protection factor (APF):</p> <p>Half mask with negative pressure: 100</p> <p>Full facepiece with positive pressure: 1000</p> | <ul style="list-style-type: none"> - Provides good protection regardless of conditions. - No need to consider which filter should be used, and whether this will protect against all contaminants. - No need to consider filter lifetime. | <ul style="list-style-type: none"> - Bottles worn on the back can be heavy to wear while working. |

Classification of full facepieces (Standard EN 136:1998)

| Class | Intended use |
|---------|---|
| Class 1 | Mainly for filtering equipment and (light duty) continual flow breathing air |
| Class 2 | Class 2 is more robust and provides greater flammability resistance |
| Class 3 | Class 3 provides the highest resistance to heat and flames (and is the class that shall be used when extinguishing fires) |

Appendix 3: Sample checklist for users of breathing air systems

NB! Several of the points included below may not be relevant to everyone.

| TRAINING | Checked (sign./NA) | Actions/Comments |
|--|---------------------------|-------------------------|
| Have personnel completed theoretical and practical training in the use of compressed air as breathing air? | | |
| Have personnel completed equipment-specific training? | | |
| MOBILE BREATHING AIR COMPRESSOR | | |
| Is the compressor located in a defined safe area, without exhaust or ventilation emissions? | | |
| Is the compressor's air intake located a sufficient distance from any sources of emissions? | | |
| Is the compressor located outside areas that require double hearing protection? | | |
| Is the compressor situated so that there is air around the entire compressor? | | |
| Is the compressor located so that the entry guard can hear the compressor's alarm/whistle? | | |
| Is the compressor oil-lubricated? If yes, the oil level shall be measured and noted here in the checklist. | | |
| If the compressor is oil-lubricated, did the measurements show approved results? Ref. EN 12021 | | |
| Has the compressor's air quality been measured and found to be in accordance with internal requirements? | | |
| Is the breathing air outlet labelled with the name and contact information of the user? | | |
| USE OF PLATFORM'S DEDICATED BREATHING AIR SYSTEM | | |
| Is the breathing air outlet that is used labelled for breathing air, and free of visible signs of damage? | | |
| Is the breathing air outlet connected to instrument air? | | |
| Has the quality of the breathing air been checked with the control room? | | |
| Has a temporary sign featuring details of who is using the breathing air been hung? (the sign shall be hung at the breathing air outlet) | | |
| Is the isolation valve or cabinet containing the isolation valve secured (Car Seal/cable ties or similar) in the open position? | | |

| | | |
|--|--|--|
| Is the filter package (with necessary filters) connected between the outlet and the user? | | |
| Are the filters in the filter unit labelled with the date and time for the next filter change? | | |
| HOSES | | |
| Are the hoses stored with protection over the openings and free from damage? | | |
| Do the hoses have a production year that is less than five years old? | | |
| Is the hose approved for breathing air (anti-static, black with green stripe)? Hose labelled 'S' for anti-static? | | |
| In the event of preheating or hot work: Is the hose approved for this and also labelled "H" (heat resistant)? | | |
| Is the hose from the breathing air outlet to the filter unit of the type "Unoflow TST 025D", "Rectus KD 25" or equivalent? | | |
| Are the hoses from the filter unit or compressor of the type "Rectus 96", "CEJN 341" or equivalent two-handed safety couplings? | | |
| Has the outlet been flushed for a minimum of 1 minute prior to connection/use? | | |
| FLITE AND FACEPIECE (MASK) | | |
| If using equipment with a regulator with overpressure – is this marked EN 14593? | | |
| Have the "Flite" and facepiece (mask) been serviced, and have they been labelled with the date and signature of a "competent person" within the past 12 months? | | |
| In the event of sandblasting, ultra-high pressure washing or welding: Is the equipment approved for this purpose? | | |
| If a combination of portable self-supplied and non-self-supplied breathing air is used: Has the volume of air in the bottle been assessed based on the relevant estimated escape time, and found to be sufficient? | | |
| WORK PERMIT | | |
| Does the work permit specify that breathing air shall be used? | | |
| Is the work permit activated? | | |

Appendix 4: Example of breathing air system – input for risk analysis

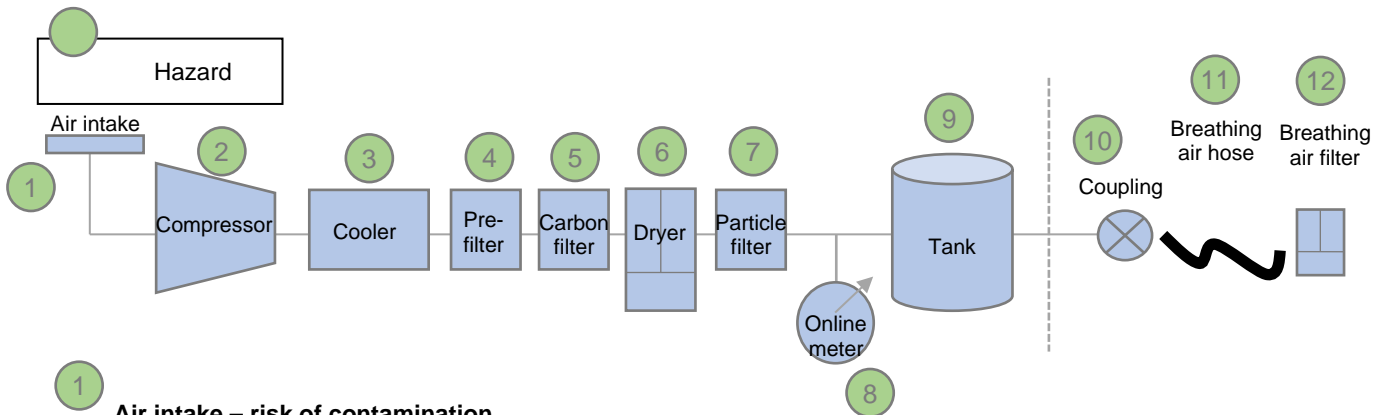

1

Air intake – risk of contamination

- Diesel motors, flaring, helicopters, boats, etc.
- Aspiration of chemicals; painting, washing, leaks, etc.

2

Compressor

- Heating of oil releases CO and gases
- Selection of oil type – must be synthetic

3

Mechanical cooler

- Possibility of contamination/infiltration

4

Pre-filter (not required – used as necessary)

- Insufficient maintenance – changing of filter

5

Carbon filter (not required – used as necessary)

- Insufficient maintenance – changing of filter

6

Dryer – maintenance routines

- Electrical heating when regenerating; smouldering (CO), short circuit
- Contamination of oil/water Pneumatic failure of regeneration

7

Afterfilter

- Maintenance – changing of filter

8

Online quality metering / breathing air (and dew point meter)

- Alarms in the event of CO/CO₂ and O₂

9

Air tank

- Insufficient cleaning of tank
- Use of incorrect cleaning agent

10

Couplings

- Risk of contamination from other systems (working air system, etc.)
- Possible to connect wrong hose types (unique couplings, labelling), or couplings may come loose

11

Breathing air hose

- Risk of the hose being used for purposes other than breathing air
- Does the hose fulfil the requirements of the environment in which it shall be used? (heat resistance, anti-static, etc.)

12

Breathing air filter

- Has a preventive maintenance programme been established?
- Does the filter have two stages? Pre-filter (removes particles) and carbon filter (removes oils and oil vapour)

Appendix 5: Checklist – design and operation of breathing air systems

| Sample checklist for approval and operation of permanent or mobile breathing air systems | | | |
|---|---|----------------|------------------|
| Parts of this list are not relevant to all types of breathing air system. The order of the equipment components may vary from system to system. A risk assessment must be carried out before using the instrument air system for breathing air purposes. The checklist must be completed, and details of any points the breathing air system does not comply with should be inserted in the comments field. | | | |
| | Equipment components | Checked | Actions/Comments |
| 1 | Air intake | Signed: | |
| | Is the location of the air intake OK with regard to possible contamination of the air entering the compressor? Possible sources of contamination include diesel motors, flaring, helicopters, boats, hydrocarbons, aspiration of chemicals, painting, washing, leaks, mud gutters, deaeration pipes from chemical tanks, etc. | | |
| 2 | Pre-filter | | |
| | Verify that the correct filter is installed and that maintenance routines have been adhered to. | | |
| 3 | Compressor | | |
| | Is the compressor oil-free? If not – is synthetic oil used? - Can the oil content be measured using system testing equipment? - Is the oiled compressor equipped with alarms for CO and high-temperature? | | |
| | When using mobile compressors, these must be designed for the supply of breathing air, and the following measurements taken: Minimum monthly: Check the quality of the breathing air (O ₂ , oil, water, CO and CO ₂) at the end user (after the filter unit). Instead of performing this check of the breathing air quality, an online meter may be used. Note: An online meter will not usually feature an oil level detector. Routines must therefore be established for periodic checks – at least twice per year and preferably once per month for systems in continuous use. Logging of the measurements is also recommended in order to monitor any developments and the need to adjust the interval of the periodic checks. Measurements shall be performed by competent personnel. The results shall be logged, and the metering equipment calibrated in accordance with supplier recommendations. Have the measurements been taken in accordance with these? Mobile compressors/systems shall be operated in accordance with the manufacturer's operation and servicing requirements, unless otherwise agreed. | | |
| | Maintenance of compressors: Compressors for breathing air shall be subject to a preventive maintenance programme, including checks of the quality of the breathing air. With regard to maintenance of the breathing air system, the following shall be documented: • Oil change / consumption of compressor oil • Check and replacement of compressor filter • Functional checks of draining and safety valves • Repairs / service performed on the system | | |

| | | | |
|----------|---|--|---|
| | <ul style="list-style-type: none"> • System irregularities • Compressor operating instructions must be available • A journal of the compressor's operating hours must be kept. All changes, repairs, replacements and air control results shall be recorded in the journal. Is all this in place? | | |
| 4 | Mechanical cooler | | |
| | Contamination/infiltration from the cooling medium may occur – has this been checked and found to be in order? | | |
| 5 | Dryer – maintenance routines | | |
| | <p>Have the following risks been handled?:</p> <ul style="list-style-type: none"> • Electrical heating during regeneration; smouldering (CO), short circuit • Oil/water contamination • Regeneration failure | | |
| 6 | Particle filter and carbon filter | | |
| | Has a preventive maintenance programme been established for particle filters and any carbon filters? | | |
| 7 | Continual quality control (when using instrument air as breathing air) | | |
| | If the limit values are exceeded, an alarm shall be sent to the party responsible for monitoring the breathing air quality, e.g. the central control room. | | FES guard shall sign for portable equipment |
| | <p>In addition to continuous quality control (ref. NS 12021), the breathing air quality (including the oil content) shall be tested:</p> <ul style="list-style-type: none"> • Min. twice per year • Following incidents that have sounded an alarm and/or contamination of the instrument air system • Prior to turnarounds and other work operations that require the extensive use of breathing air <p>The location at which the tests are taken should be varied, and the results logged. Metering equipment shall be calibrated in accordance with supplier recommendations.</p> | | |
| | Online meters shall be checked a minimum of once per year, or as recommended by the supplier. | | |
| | Verify that any external (and back-up) air compressors do not supply air downstream of (after) the online meter. It is recommended that the online meter is placed after the drying system and before the air tank / bottle bank, since a certain response time is required in the event of an alarm. | | |
| 8 | Air tank (including bottle bank) | | |
| | <p>If the control measurement of the breathing air sounds an alarm, or if the air supply fails, there must be sufficient time for users of the breathing air to move to a safe area, e.g. if contaminated air reaches the users (a breathing air user may use up to 500 litres per minute). Has this been taken into account?</p> <p>The use of breathing air is not permitted during work involving the shutdown of compressed air tanks.</p> | | |
| | If the breathing air system has been cleaned internally using detergents or chemicals, the system shall be flushed and the air quality measured and found to be at an acceptable level. | | |
| | Bottle banks shall be maintained in the same way as compressed air cylinders in accordance with relevant regulations. | | |
| 9 | Distribution system | | |
| | Verify that there are physical barriers which ensure that contaminants from other systems connected to the instrument air system cannot flow back into the system, e.g. N ₂ from nitrogen compressor. | | |
| | Verify that there are physical barriers which ensure that working air cannot flow back into the instrument air system (e.g. non-return valve). No valves | | |

| | | | |
|-----------|---|--|--|
| | which automatically close in the event of an alarm or poor air quality shall be installed. Has this been checked? | | |
| 10 | Couplings/outlet | | |
| | Have dedicated outlets for breathing air been established in order to prevent contaminants from other systems and hoses entering the breathing air? The outlets must not be located before online meters or breathing air tanks. The outlets shall be labelled "Outlet for breathing air only" and feature unique, approved two-handed couplings which are different from couplings used for other media/purposes. Any outlets from the instrument air network to other systems (e.g. drilling-sensitive equipment requiring overpressure) must be labelled in order to avoid unintentional/incorrect use. | | |
| | Are standard couplings currently in use? When connecting equipment from the breathing air outlet to the filter unit, coupling types Unoflow TST 025D, Rectus KD 25 or equivalent breathing air equipment couplings from other manufacturers shall be used. Couplings on equipment after the filter unit to the end user shall be the same as for ordinary breathing air systems: Rectus 96, CEJN 341 (or equivalent identical couplings from other manufacturers). | | |
| 11 | Hoses for breathing air | | |
| | Breathing air hoses (from the filter unit to the end user) and supply hoses (from the air intake to the filter unit) shall be uniquely for use with breathing air equipment, anti-static both internally and externally, and heat resistant. The hoses shall be designed and tested in accordance with EN 14593 / EN 14594. | | |
| | Like other hoses, breathing air hoses, couplings and their associated seals shall be checked regularly and found to be free from damage. | | |
| 12 | Breathing air filter | | |
| | When using breathing air from the instrument air system, filter units that remove particles, oil mist/vapour and water vapour / steam shall always be used at the end user. Verify the date of the last filter change (to end user). | | |
| | A log of equipment maintenance and lending shall be kept. Filter units (stationary and mobile): <ul style="list-style-type: none"> • Each unit shall be labelled with its own "tag" number • The filter shall be marked with the installation date and expiry date / date of next filter change during installation • Filter changes may be based on the pressure drop indicator, colour indicator and the number of operating hours (in accordance with the manual). All filters shall be changed a minimum of once per year due to the risk of microorganism growth. | | |

Appendix 6: Technical info

Appendix 6.1 Dimensioning

One user requires an air flow of up to 300 litres per minute, with 150 litres per minute calculated for the second user. Permanently installed breathing air systems are usually dimensioned for a large number of users, and any limitations will be imposed by the work permit system.

Mobile breathing air compressors should have capacity for a minimum of two users (due to emergency preparedness considerations).

The system should include a pre-heating system if it is to be used in low temperatures. This is to prevent frost damage, and to ensure that the mask does not become stiff and therefore break its seal. Note that mechanical pre-heaters “consume” air, and one must therefore be aware of possible capacity problems when using such equipment in combination with mobile filter units (used on fixed installations).

Appendix 6.2 Maintenance of breathing air systems

In accordance with regulations¹, written instructions for the operation and maintenance of compressed air and filling systems must be available, and the quality of the breathing air must be regularly checked. Appendix 1 may be used as input for a risk analysis and review of the breathing air systems in order to ensure high-quality breathing air.

A review of the breathing air systems should include the following:

- Risk analysis – which standards and barriers are used?
- Division of responsibilities and training needs
 - To be clarified between the system owner and users
- Procedures relating to training, maintenance, monitoring, use and labelling

Appendix 6.3 Couplings and hoses for use with breathing air

Hoses used for the distribution of breathing air should be clearly labelled, anti-static both internally and externally, and heat resistant. They must not release any odour, taste or harmful gases during use. The hoses must be stiff enough to prevent the air supply from being blocked if they are trodden on or kinked.

The breathing air system shall feature unique, approved, two-handed safety couplings that cannot be connected to other systems. The couplings before and after the filter unit shall be different, in order to prevent breathing air equipment being directly connected to the breathing air outlet.

Details of the requirements relating to hoses and couplings are provided in NS-EN 14593-1⁶ and 2, as well as NS-EN 14594⁷. Where several different types of couplings are used, the client should be contacted to ensure that the relevant hoses and equipment are compatible.

When connecting equipment from the breathing air outlet to the filter unit, coupling types “Unoflow TST 025D”, “Rectus KD 25”, or equivalent breathing air equipment couplings from other suppliers are usually used:



When connecting equipment from the filter unit to the breathing air user, coupling types “Rectus 96”, “CEJN 341” or equivalent two-handed safety couplings for breathing air equipment from other suppliers are usually used. It is not permitted to change or adapt incompatible couplings:



Appendix 6.4 Bottle banks

Bottle banks used to store breathing air usually consist of bottles of compressed air with a volume of 50 litres and a filling pressure of 200 or 300 bar.

The bottle banks may be located together with a filling station (high-pressure compressor) or as a free-standing bank to supply a breathing air line via a pressure regulator and connection manifold.

The air quality shall satisfy the requirements given in NS-EN 12021 and the Regulations concerning action and limit values².

The Regulations concerning the performance of work¹ set requirements regarding the inspection, labelling and filling of breathing air equipment for diving and respiratory protection.

Pressurised bottles of compressed air at 200 or 300 bar shall be subject to periodic pressure testing intervals (five years for bottles used for breathing air on land).



Following pressure testing, the shoulder of the bottle is stamped with the month and year, and a ring which identifies the bottle and who has performed the pressure test.

The image shows a bottle that has been pressure tested in September (09) 2015 (15). The round mark to the right of the number 15 contains 'Å' and '76'. 'Å' shows that the bottle contains breathing air for use on land (bottles for diving are marked 'D'), and that the test has been performed by the controller with registration number 76.